

Linear Kiosk 04

LN-K-04

Dress up and add wow to your space with state-of-the-art multimedia kiosks.



We are continually improving and modifying our product range and reserve the right to vary the specifications without prior notice. All dimensions and weights quoted are approximate and we accept no responsibility for variance. E&OE. See Graphic Templates for graphic bleed specifications.

features and benefits:

- Custom appearance
- Easy to assemble
- Bases available in four finishes
- Aluminum construction: vertical extrusions 50 mm x 50 mm
- 50 watt low voltage lighting
- Wings are double sided
- Installation tool included
- Kit includes one OCH2 case, rigid custom printed wing and center graphic panels and one 50 watt spotlight
- Easy step-by-step instructions
- Lifetime hardware warranty against manufacturer defects

dimensions:

Hardware	Graphic
<p>Assembled unit: 63" w x 96.85" h x 30" d approx. 1600mm(w) x 2460mm(h) x 762mm(d)</p>	<p>Top wings: Total visible area: 17.17" w x 46.06" h 436.118mm(w) x 1169.924mm(h)</p>
<p>Shipping</p> <p>Shipping dimensions - ships in one case OCH2 case: 52" l x 30" w x 15" h 1320.8mm(l) x 762mm(w) x 381mm(h)</p> <p>Approximate shipping weight (entire kit): 90lbs/40.8kg</p>	<p>Bottom wings: Total visible area: 13" w x 46.06" h 330.2mm(w) x 1169.924mm(h)</p> <p>Center graphic: Total visible area: 43.30" w x 23.62" h 1099.82mm(w) x 599.948mm(h)</p> <p>Refer to related graphic template for more information</p>

additional information:

Graphic materials:
UV prints on 6mm sintra

Base color options:

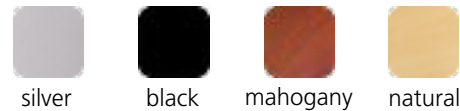

Wing and center panel graphics can be upgraded to frosted plex

Light included: LV1 50 watt, low voltage spotlight, curved arm, silver finish, 19.5" from end to end

Parts Included		
Part label	Qty	Part code
VE-16	x4	PH-600-S-S
VE-36	x4	PM2R8-1200-A-A
VE-45	x2	PH4-300
V-K-B-01	x1	V-K-B-01
V-K-B-02	x1	V-K-B-02
V-K-L-02	x2	V-K-L-02
V-K-L-01	x2	V-K-L-01
Graphic A	x2	-
Graphic B (t. wing)	x1	-
Graphic C (b. wing)	x1	-
Graphic D (t. wing)	x1	-
Graphic E (b. wing)	x1	-
Standoff (wings)	x8	CKAPS
Standoff (center)	x4	CKSO
Light	x1	V-LV1-CL
VE-35	x1	WME-600
VE-64	x1	WME-450
VE-65	x1	WME-1200
Joining bar	x4	LN100
T-Handle	x1	T-HANDLE

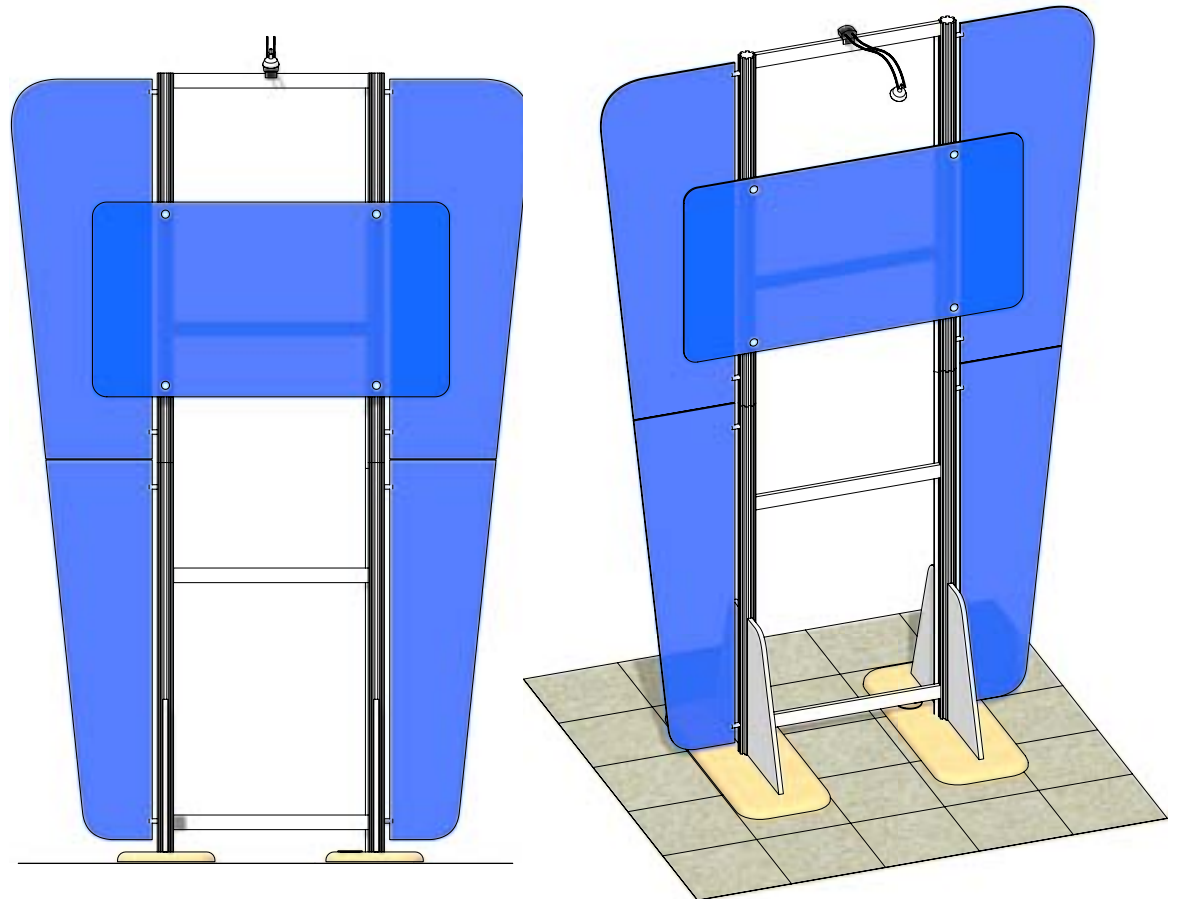

Step 1.

Attach VE-36 verticals to kiosk feet using detail below.

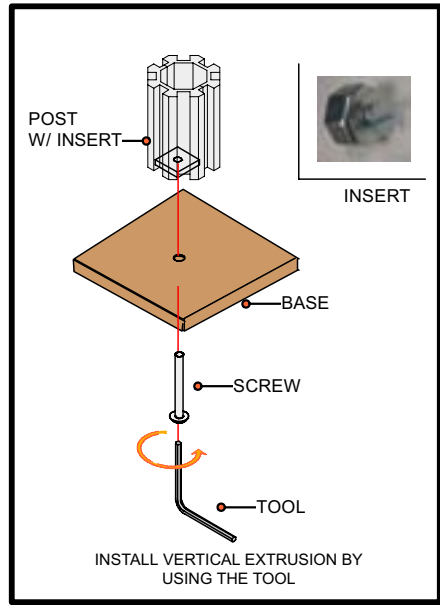
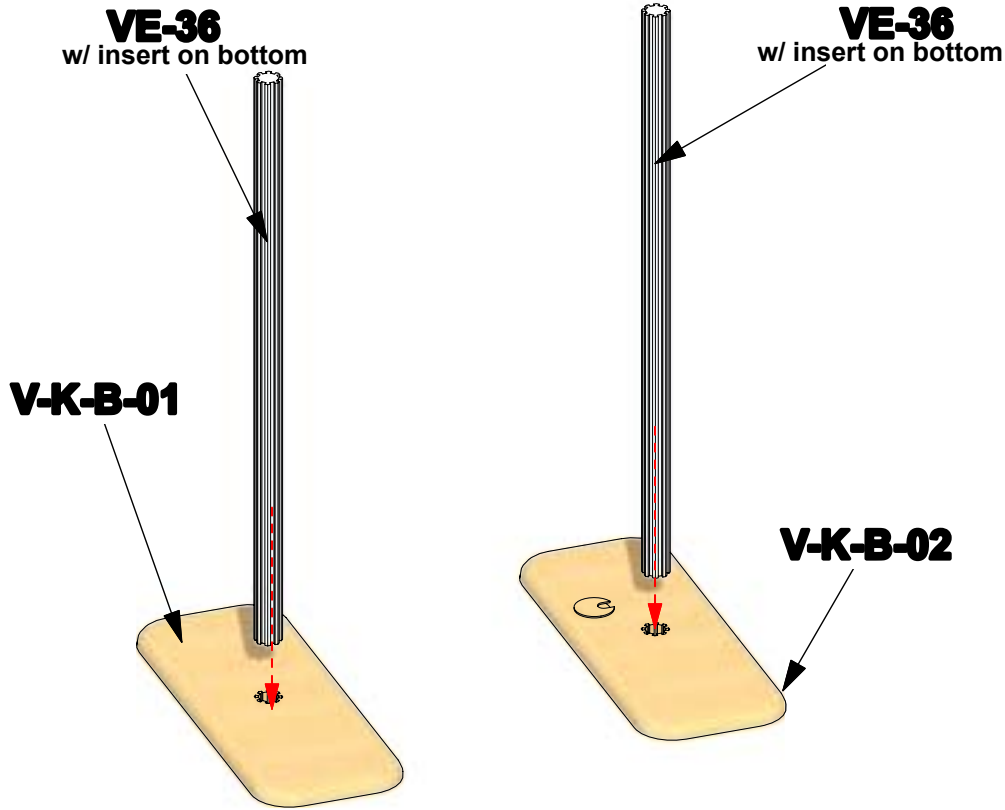

Step 2.

Connect V-K-L-01s to the VE-36 uprights using detail below. Lock holes should face inside.

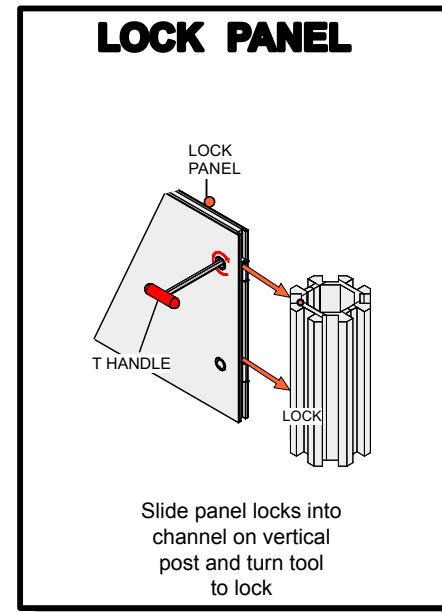
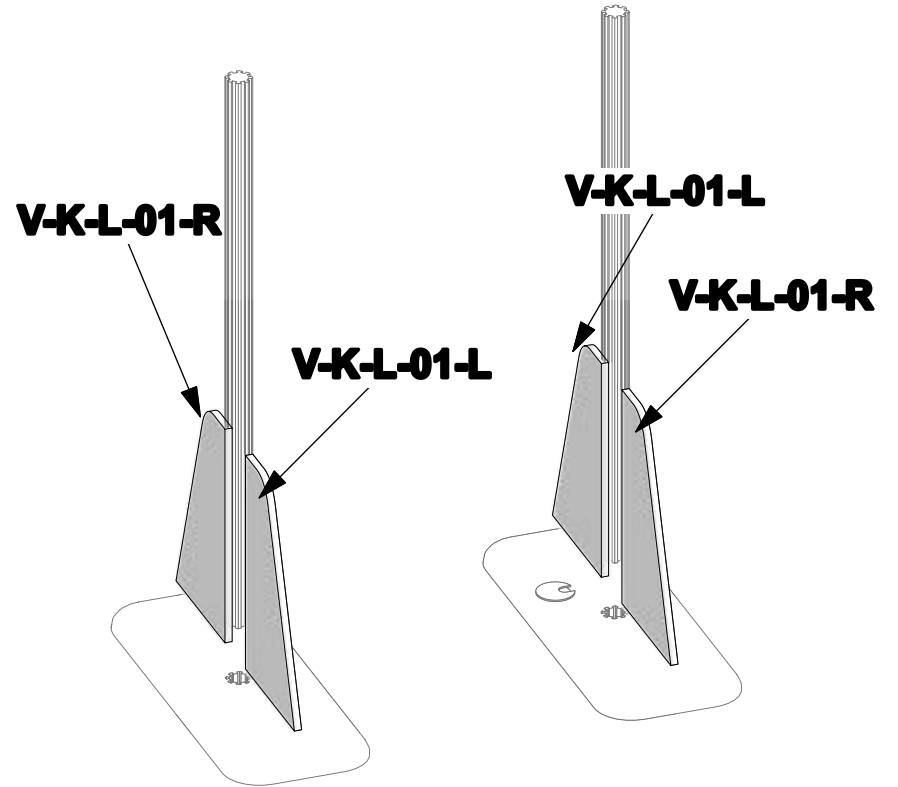

Step 3.
 Insert VE-45 internal connectors into lower VE-36s. Attach joining bars to lower VE-36s. Slide upper VE-36s onto the joining bars and VE-45 internal connectors. Lock joining bars.

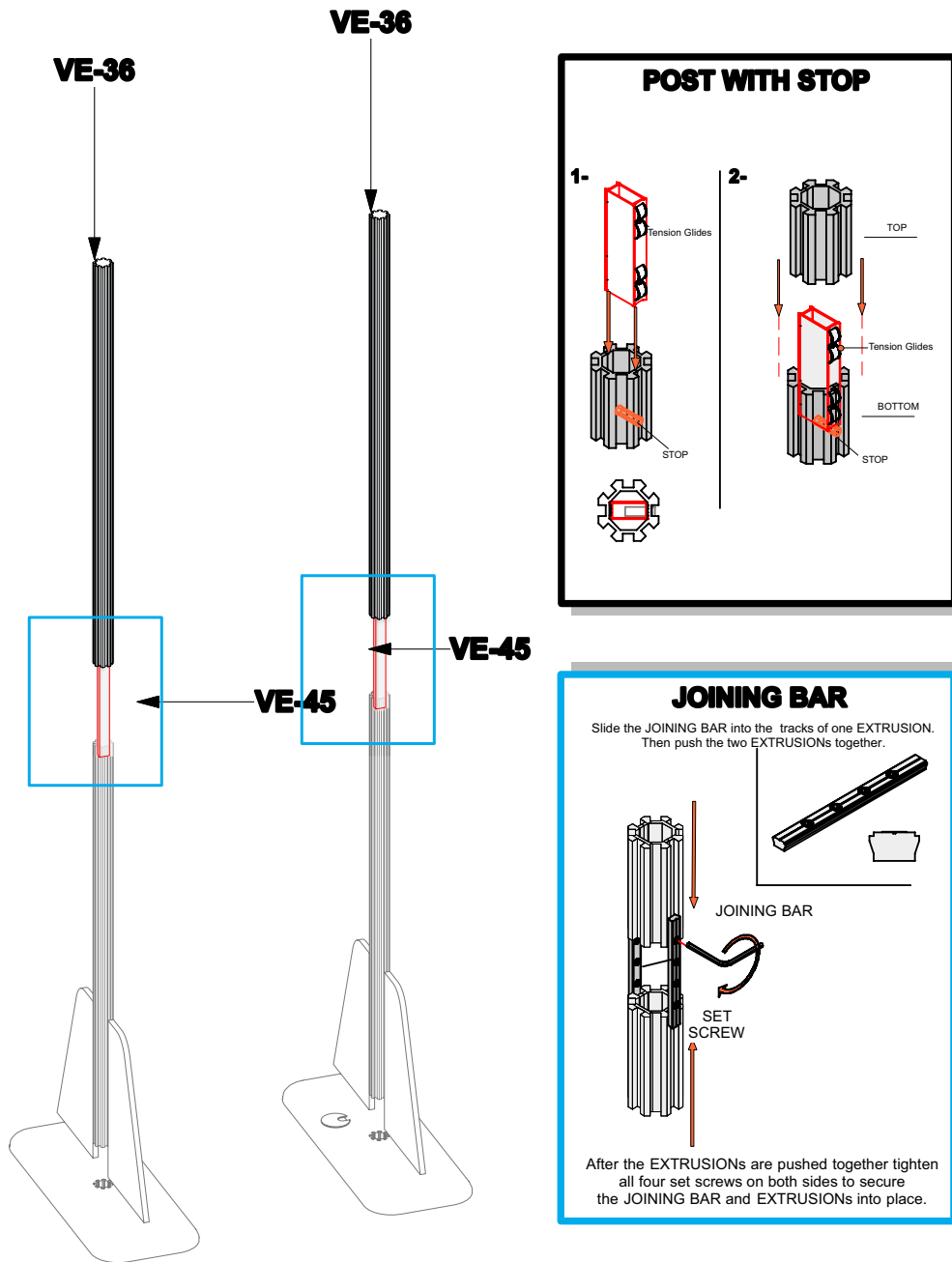

Step 4.
 Attach VE-16s between uprights at specified heights using detail shown below. Assure that the top VE-16 lines up at the top of the uprights, and the bottom VE-16 lines up at the bottom of the uprights.

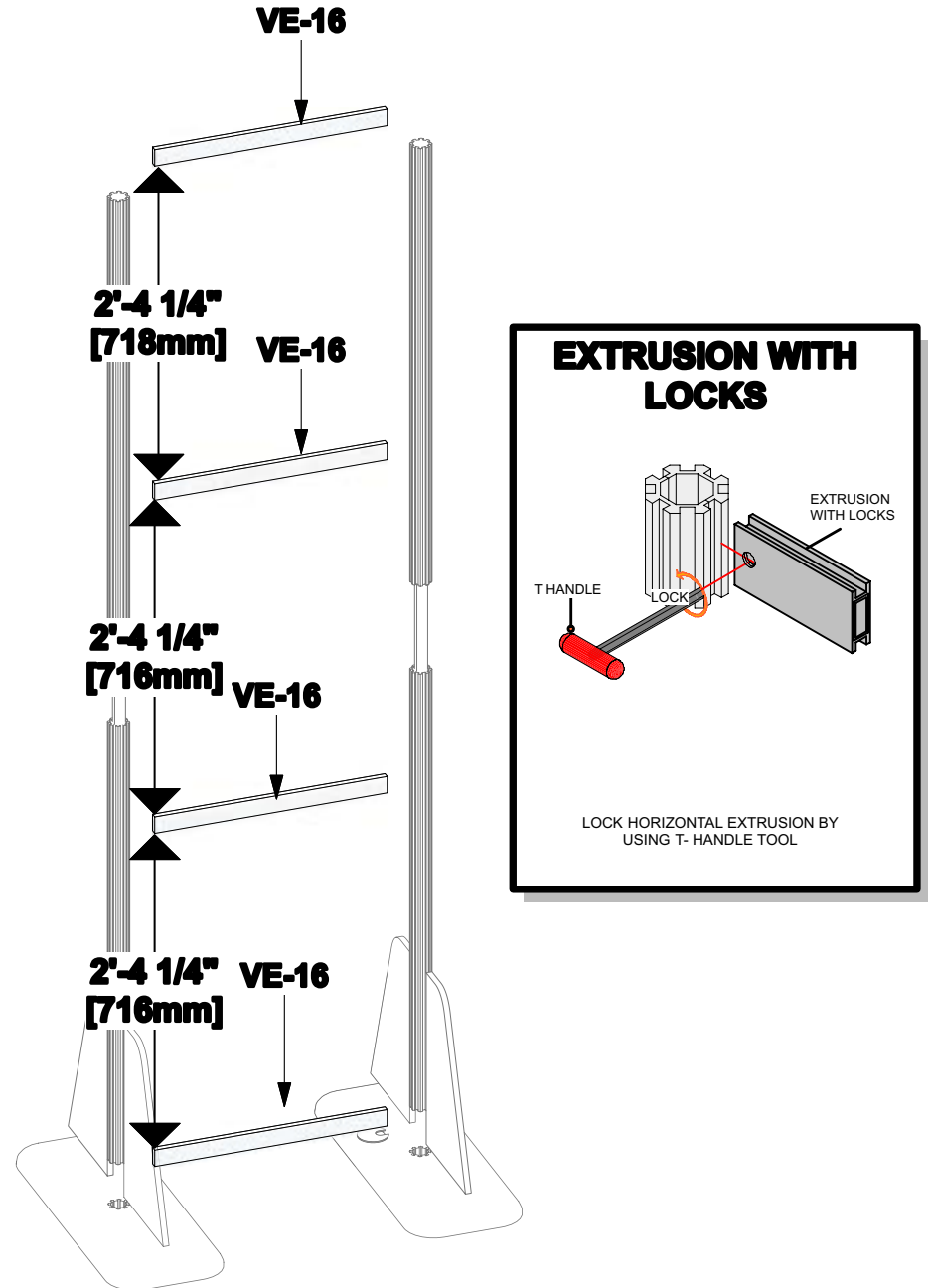

Step 5.

Attach standoffs to VE-36s in designated positions. Attach wings to standoffs.

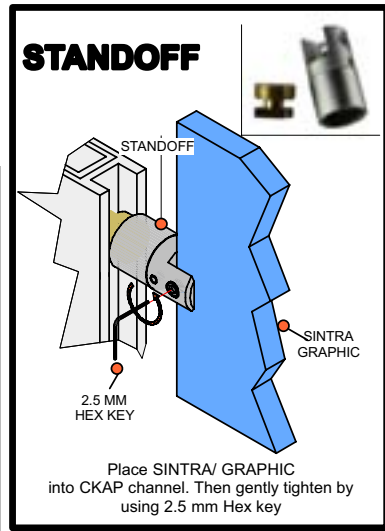
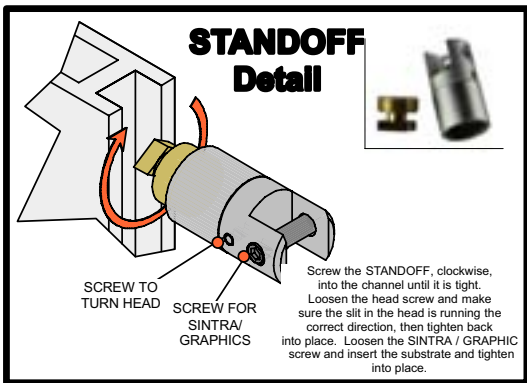
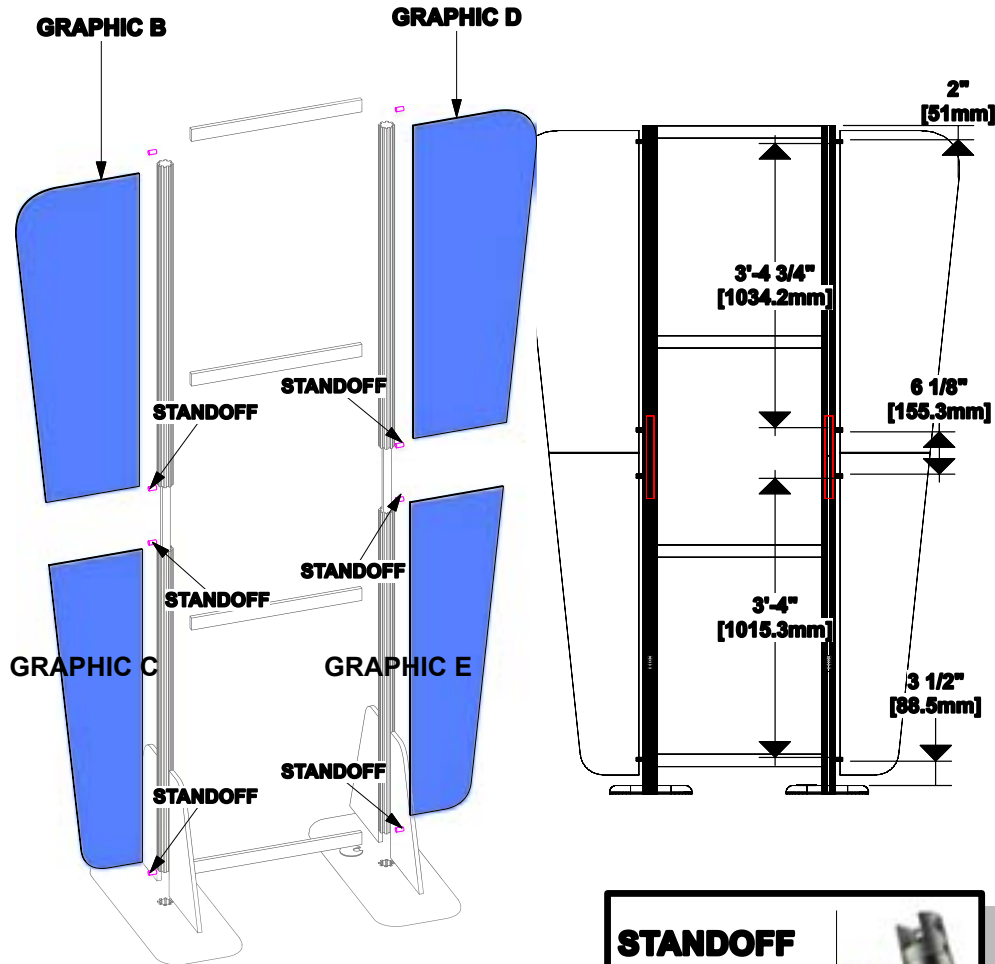

Step 6.

Attach standoffs to front of VE-36s. Attach front center graphic to standoffs.

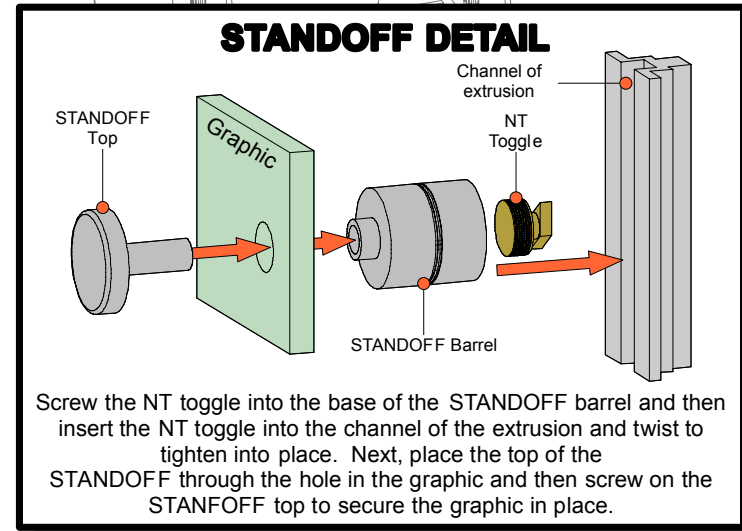
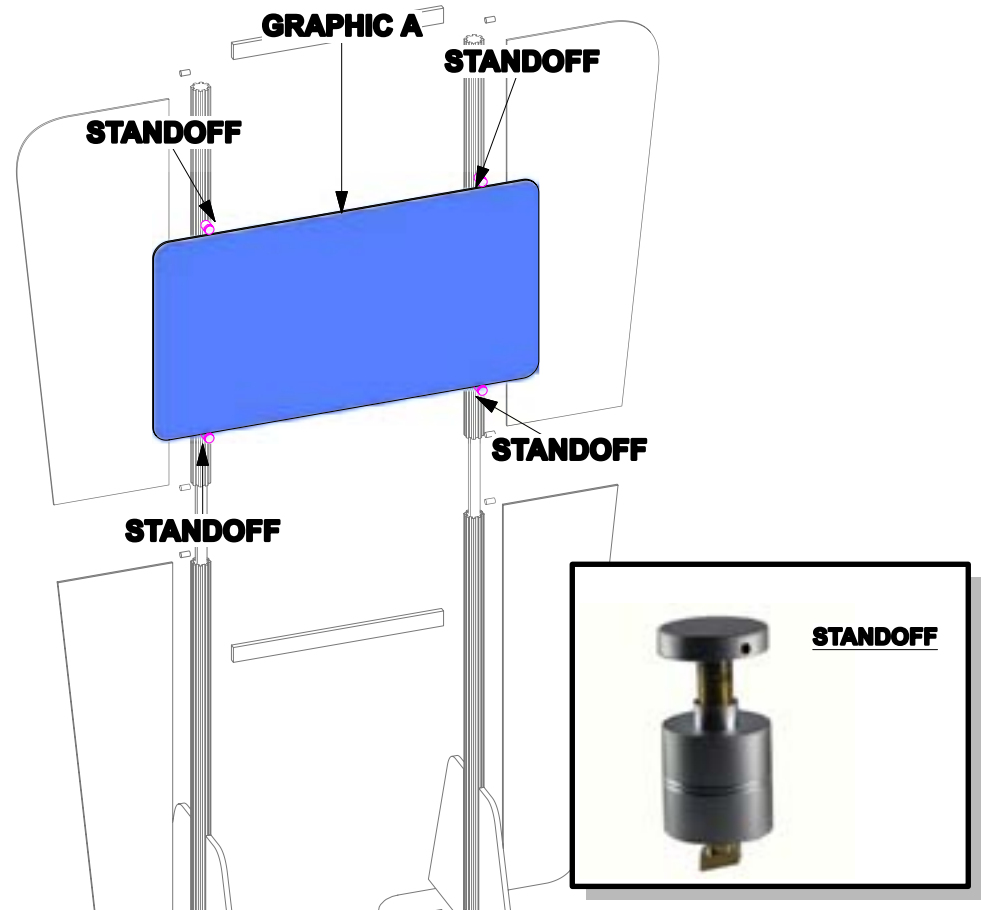

Step 7.

Slide light onto clip and place clip in channel on VE-16 as shown in detail below. Run light cord through VE-35, VE-64, VE-65 with light switch between VE-35 and VE-64. Snap into channel leaving the space behind the graphic.

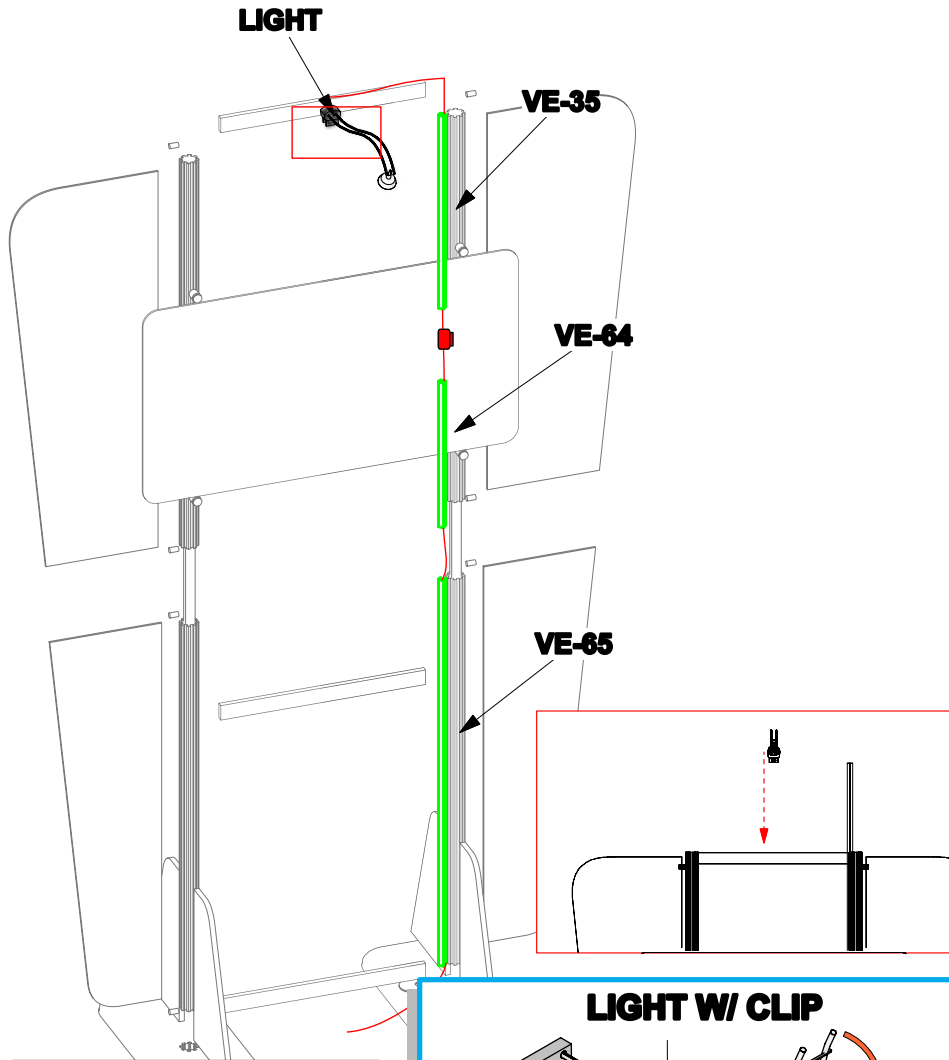

LV1 Light

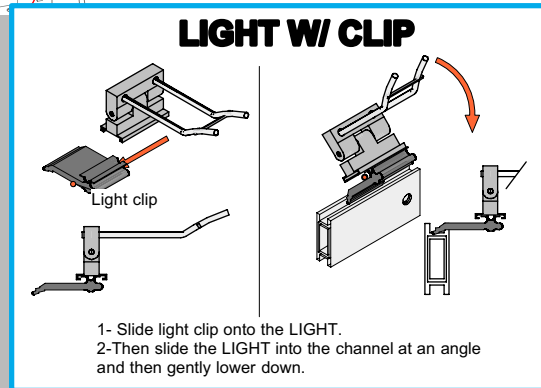

Step 8.

Attach standoffs to back of verticals. Attach back graphic to standoffs.

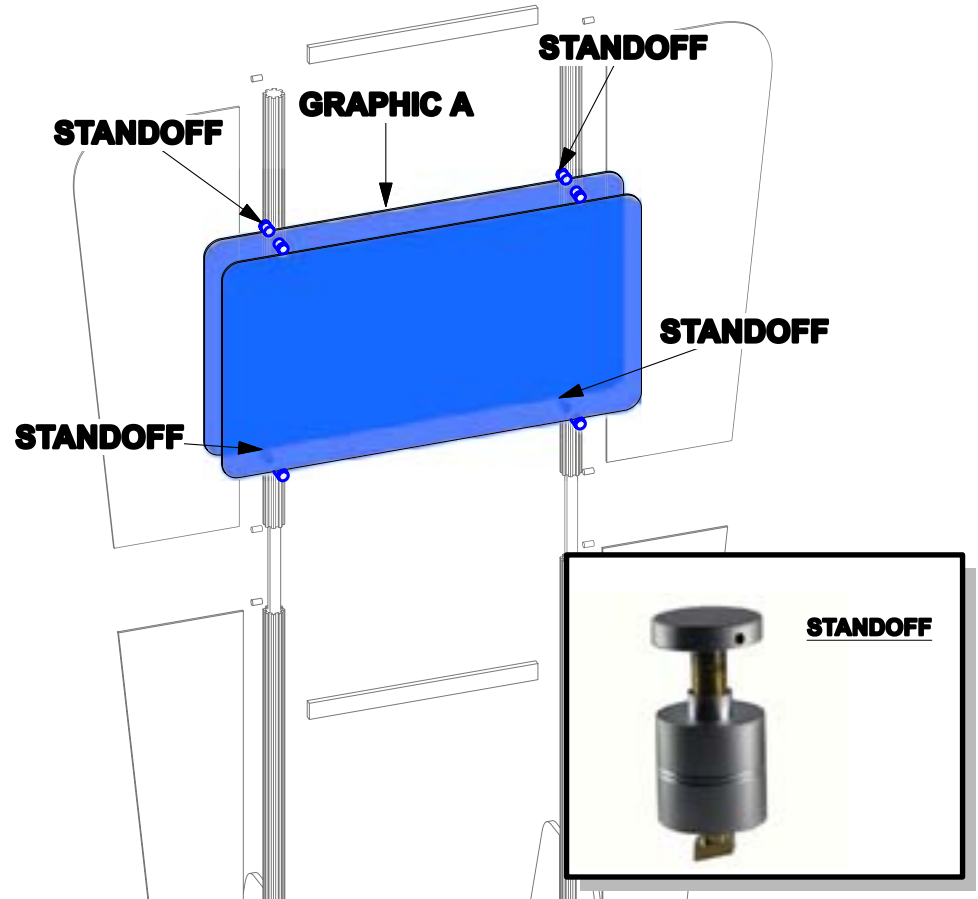

STANDOFF

